

# RNAV (GPS) RWY 28

EAST HAMPTON (HTO)

APP CRS	Rwy Idg	<b>4255</b>
<b>282°</b>	TDZE	<b>46</b>
	Apt Elev	<b>55</b>

**▽** DME/DME RNP-0.3 NA.  
**△** NA Visibility reduction by helicopters NA.  
 Obtain local altimeter setting on CTAF; when not received, use Westhampton Beach altimeter setting.

MISSED APPROACH: Climb to 2000 direct MATHW and hold.

NEW YORK APP CON  
**125.975 343.65**

CLNC DEL  
**118.95**

UNICOM  
**122.7 (CTAF)**

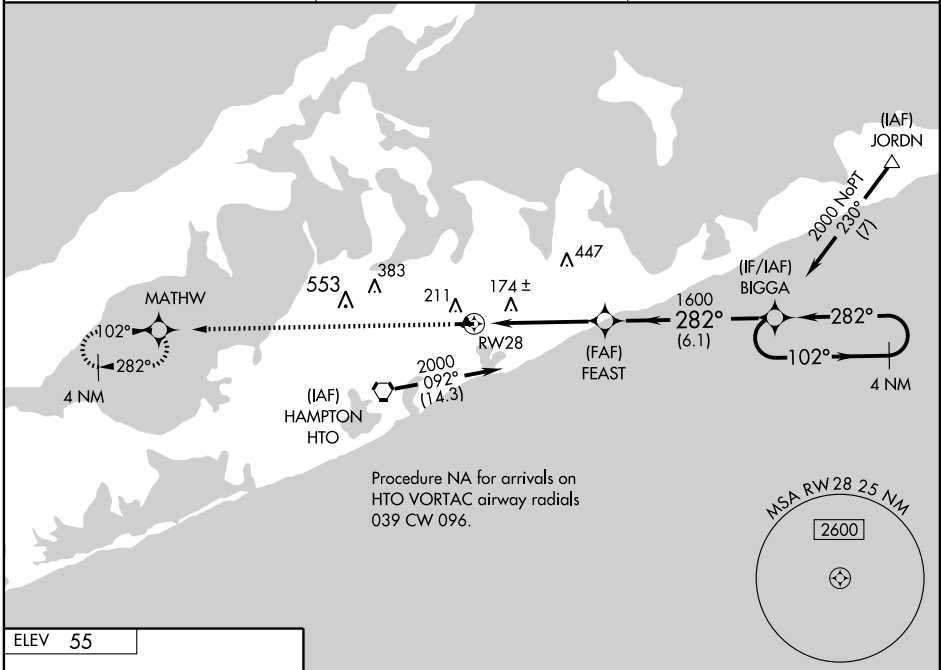

NE-2, 19 NOV 2009 to 17 DEC 2009

NE-2, 19 NOV 2009 to 17 DEC 2009

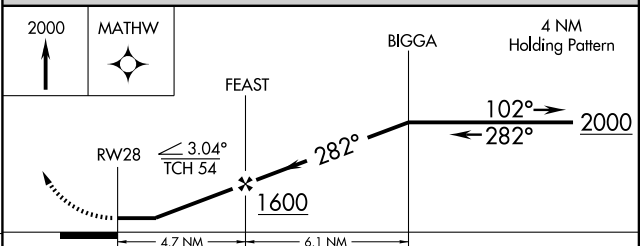
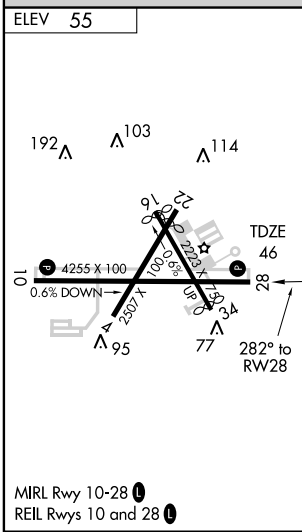

CATEGORY	A	B	C	D
LNAV MDA	440-1 394 (400-1)			440-1¼ 394 (400-1¼)
CIRCLING	560-1	505 (600-1)	560-1½ 505 (600-1½)	620-2 565 (600-2)
WESTHAMPTON BEACH ALTIMETER SETTING MINIMUMS				
LNAV MDA	480-1	434 (500-1)	480-1¼ 434 (500-1¼)	480-1½ 434 (500-1½)
CIRCLING	600-1	545 (600-1)	600-1½ 545 (600-1½)	620-2 565 (600-2)