

APP CRS 155°	Rwy ldg TDZE Apt Elev	5010 127 127
------------------------	-----------------------------	---

RNAV (GPS) RWY 15

EMPORIA-GREENSVILLE RGNL (EMV)

Procedure NA at night. DME/DME RNP-0.3 NA. When local altimeter setting not received, use Ahoskie altimeter setting and increase all MDA 80 feet.

MISSED APPROACH: Climb to 2000 direct XETY and hold.

AWOS-3 124.175	WASHINGTON CENTER 132.025 269.4	UNICOM 123.0 (CTAF) 0
--------------------------	---	---------------------------------

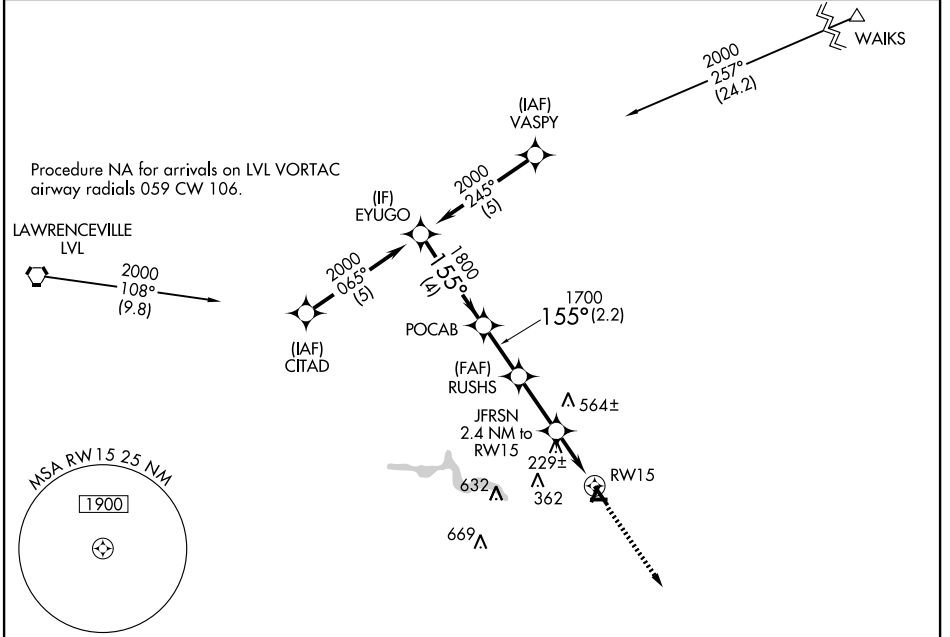

NE-3, 11 MAR 2010 to 08 APR 2010

NE-3, 11 MAR 2010 to 08 APR 2010

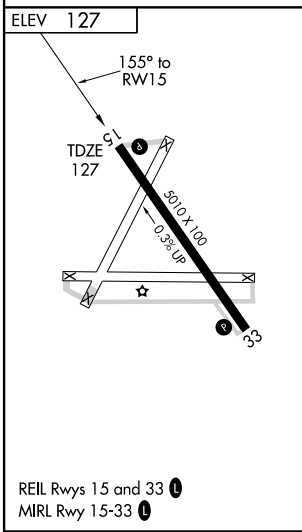

Procedure Turn NA	EYUGO 2000	POCAB 1800	RUSHS 1700	JFRSN 2.4 NM to RWY 15 920	RWY 15
	4 NM	2.2 NM	2.4 NM	2.4 NM	
CATEGORY	A	B	C	D	
LNAV MDA	480-1	353 (400-1)	NA	NA	
CIRCLING	560-1 433 (500-1)	580-1 453 (500-1)	NA	NA	

Missed Approach: Climb to 2000 direct XETY and hold.