

DURANT, OKLAHOMA

AL-6172 (FAA)

VOR/DME URH 114.3 Chan 90	APP CRS 004°	Rwy Idg TDZE Apt Elev	5001 695 698
---	------------------------	-----------------------------	---

VOR/DME RWY 35

DURANT/ EAKER FIELD (DUA)

NA If local altimeter setting not received, use Ardmore Muni altimeter setting and increase all MDAs 100 feet. VDP NA when using Ardmore Muni altimeter setting.

MISSED APPROACH: Climb to 2500 in URH VOR/DME holding pattern.

AWOS-3 124.175	FORT WORTH CENTER 124.75 377.1	UNICOM 122.8 (CTAF) 0
--------------------------	--	---------------------------------

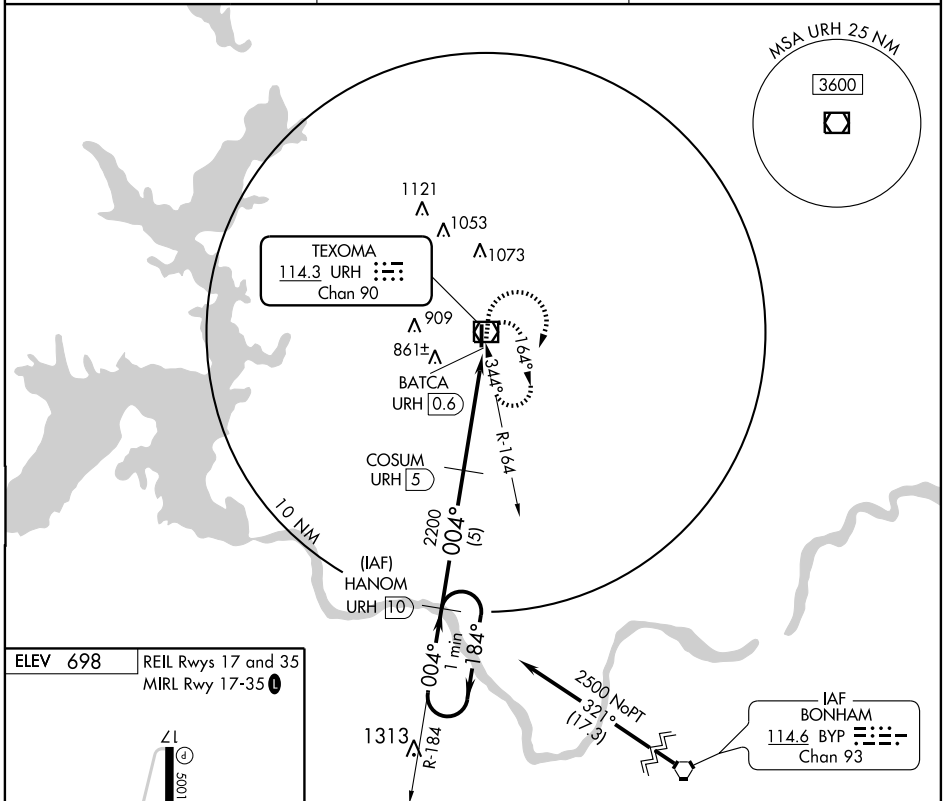

SC-1, 19 NOV 2009 to 17 DEC 2009

SC-1, 19 NOV 2009 to 17 DEC 2009

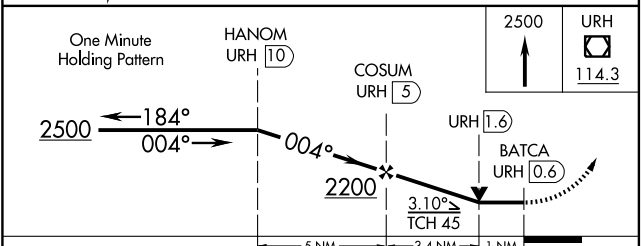
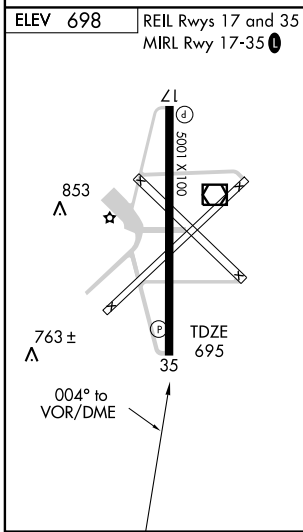

CATEGORY	A	B	C	D
S-35	1060-1	365 (400-1)		NA
CIRCLING	1160-1	462 (500-1)	1160-1½ 462 (500-1½)	NA

DURANT, OKLAHOMA
Orig 09183

33° 57' N-96° 24' W

DURANT/ EAKER FIELD (DUA)

VOR/DME RWY 35